

# Using Plan Recognition in Human-Computer Collaboration

Neal Lesh<sup>1</sup>, Charles Rich<sup>1</sup> and Candace L. Sidner<sup>2</sup> \*  
{lesh, rich}@merl.com, csidner@lotus.com

<sup>1</sup> MERL—A Mitsubishi Electric Research Laboratory  
<sup>2</sup> Lotus Development Corporation

**Abstract.** Human-computer collaboration provides a practical and useful application for plan recognition techniques. We describe a plan recognition algorithm which is tractable by virtue of exploiting properties of the collaborative setting, namely: the focus of attention, the use of partially elaborated hierarchical plans, and the possibility of asking for clarification. We demonstrate how the addition of our plan recognition algorithm to an implemented collaborative system reduces the amount of communication required from the user.

## 1 Introduction

An important trend in recent work on human-computer interaction and user modeling has been to view human-computer interaction as a kind of *collaboration* (e.g, Ferguson and Allen, 1998, Guinn, 1996, Rich and Sidner, 1998, Rickel and Johnson, 1998). In this approach, the human user and the computer (often personified as an “agent”) coordinate their actions toward achieving shared goals. A common setting for collaboration, illustrated in Figure 1(a), and which is the focus of this paper, is when two participants can both communicate with each other and observe each other’s actions on some shared artifact.

Successful collaboration requires the participants to have substantial mutual understanding of their shared goals and the actions intended to achieve them (these are part of what Grosz and Sidner (1990) call the *SharedPlan*). One way to maintain this mutual understanding is through verbal communication—the participants can explicitly discuss each goal and the method they propose to achieve it. However, it is often more efficient and natural to convey intentions by performing actions. For example, if two people are attempting to get into their locked car and one picks up a brick, the other can infer that the proposed plan is for the first person to smash a window, reach in, and unlock the door. *Plan recognition* (e.g., Carberry, 1990, Kautz and Allen, 1986) is the term generally given to the process of inferring intentions from actions.

Although plan recognition is a well-known feature of human collaboration, it has proven difficult to incorporate into practical human-computer collaboration systems due to its inherent intractability in the general case (see Section 2.1). In this work, we describe how to exploit properties of the collaborative setting in order to make plan recognition practical. Specifically, the properties we exploit are: the focus of attention, the use of partially elaborated hierarchical plans, and the possibility of asking for clarification.

We demonstrate our approach in the context of an implemented collaborative system for email. Section 1.1 below presents two example sessions with this system. Section 2 describes the

---

\* Thanks to Jeff Rickel for his insightful comments on an earlier draft of this paper.

underlying plan recognition and discourse interpretation algorithms in detail. We then discuss related work and conclude.

### 1.1 Collagen Email Example

Collagen (Rich and Sidner, 1998) is an application-independent collaboration manager based on the SharedPlan theory of task-oriented collaborative discourse (e.g., Lochbaum, 1998). We are currently experimenting with Collagen in several different application areas, including air travel (see Grosz and Kraus, 1996, Rich and Sidner, 1998) and email.

Figure 1(b) shows how the abstract setting for human-computer collaboration in Figure 1(a) is instantiated using Collagen in the email domain. The large window in Figure 1(b) is the graphical interface to the email part of Lotus eSuite™; this is the “shared artifact” of the collaboration. The two smaller, overlapping windows in the corners of Figure 1(b) are the agent’s and user’s *home windows*, through which they communicate with each other.

For an application-independent tool like Collagen, a key step in building a collaborative agent is to develop a detailed task model for the domain. Based on empirical study of people working on email, Sidner and colleagues have formalized the task structure of this domain in terms of high-level goals, such as “working on email”, lower-level goals, such as “filling in a message,” and primitive actions corresponding to individual clicks on the eSuite interface.

**Without Plan Recognition.** Let us look first at the left column of Figure 1(c), which shows how Collagen functions without plan recognition. In the first part of this session (lines 1–8) the user has the initiative. Notice how the user laboriously announces each goal before performing a primitive action which contributes to achieving it. Without plan recognition, this is the only way to maintain the mutual understanding necessary for successful collaboration.

A simple example of collaboration occurs after the user returns from a long lunch (line 9). At this point, the user’s earlier intentional state is not immediately evident from the state of the graphical interface, which would show only a browser window (resulting from clicking on a URL in the message being read) with the email window behind or below it. Based on the user’s earlier announcement of goals, however, the agent has constructed a SharedPlan, which it can communicate back to the user (lines 11–16) to help him reorient to what he was doing and what is expected next.<sup>1</sup>

The user now continues as before, announcing his subgoals as he goes, until line 27, when he declares that he is done with the goal of filling in the new message started in line 19. The agent uses this as an opportunity to suggest some expected actions (line 28), one of which the user requests the agent to perform (lines 29–30).

**With Plan Recognition.** The right column of Figure 1(c) shows the same task as the left column, but with our plan recognition algorithm incorporated into Collagen. Notice that, unlike the previous example, the user in this session is not required to announce each goal and subgoal before performing a primitive act (i.e., lines 3, 5, 7, 17, 18, and 20 are missing). Nevertheless, as we see in lines 11–16, the agent constructs the same SharedPlan as before.

Plan recognition does not, however, totally eliminate the need for communication about intentions. In particular, collaborators must ask for clarification when there is ambiguity regarding

---

<sup>1</sup> The agent’s communication in lines 11–16 derives from a more general capability in Collagen for maintaining what is called a *segmented interaction history*—see Rich and Sidner (1998).

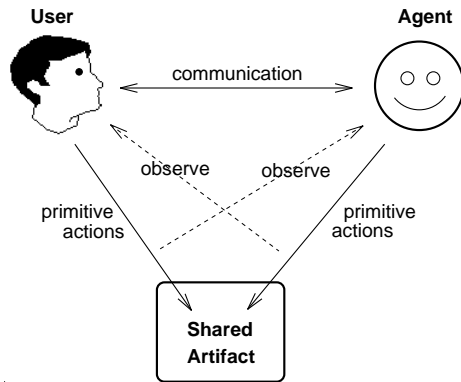

(a) A setting for human-computer collaboration.

(b) Graphical interface for email collaboration.

without plan recognition

with plan recognition

<pre> 1 USER: "Let's work on email." 2 AGENT: "You have 5 unread messages." 3 USER: "Let's read a message." 4 USER: &lt;Select message from Chuck&gt; 5 USER: "Let's read message in its own window." 6 USER: &lt;Open message&gt; 7 USER: "Let's do something using message." 8 USER: &lt;Visit http://foo.bar.com&gt; 9   ...long lunch... 10 USER: "What was I doing?" 11 AGENT: "Working on email. 12   Reading message from Chuck. 13   Reading message in its own window. 14     Done something using message. 15     &lt;Visit http://foo.bar.com&gt; 16     Expecting to react to message." 17 USER: "Let's react to message." 18 USER: "Let's send email." 19 USER: &lt;Start new message&gt; 20 USER: "Let's fill in message." 21 USER: &lt;Address message to Dan&gt; 22 23 24 25 26   ...additional editing actions... 27 USER: "Done filling in message." 28 AGENT: "Let's send, cancel or save msg." 29 USER: "Please save message." 30 AGENT: &lt;Save message&gt; </pre>	<pre> USER: "Let's work on email." AGENT: "You have 5 unread messages." USER: &lt;Select message from Chuck&gt; USER: &lt;Open message&gt; USER: &lt;Visit http://foo.bar.com&gt;   ...long lunch... USER: "What was I doing?" AGENT: "Working on email.   Reading message from Chuck.   Reading message in its own ...     Done something using message.     &lt;Visit http://foo.bar.com&gt;     Expecting to react to message." USER: &lt;Start new message&gt; USER: &lt;Address message to Dan&gt; AGENT: "Why you sending email to Dan?   (a) reacting to msg from Chuck   (b) as a new goal " USER: "I'm reacting to msg from Chuck."   ...additional editing actions... USER: "Done filling in message." AGENT: "Let's send, cancel or save msg." USER: "Please save message." AGENT: &lt;Save message&gt; </pre>
--	---

Key: "utterance" <primitive action>

(c) Collagen email session with and without plan recognition.

Figure 1.

how to interpret some given actions. For example, the user's actions in lines 19 and 21 are consistent with two possible intentions: by sending a message to Dan, the user may either be reacting to the message from Chuck (for example, if Chuck suggested sending email to Dan) or be starting a new, unrelated email goal. The agent interrupts the user at line 22 to resolve this ambiguity.<sup>2</sup> Section 2.2 discusses strategies for composing clarification questions.

## 1.2 The Role of Plan Recognition in Collaboration

This section previews the main points presented in the remainder of the paper, abstracted away from the details of the example above.

According to SharedPlan theory, a key component of the mental state of each participant in a collaboration is a set of beliefs about the mutually believed goals and actions to be performed, and about the mutually believed capabilities, intentions, and commitments of each participant. Each participant updates this set of beliefs, called the *SharedPlan*, based in part on communication with and observation of the other participants. Each participant also knows a set of methods, called *recipes*, for decomposing goals into subgoals.

Generally speaking, the role of plan recognition in this framework is as follows: Suppose one participant, e.g., the software agent, observes another participant, e.g., the user, perform an action *A*. The agent invokes plan recognition to determine the set of possible extensions to its current SharedPlan which are consistent with its recipe knowledge and include the user performing *A*. If there is exactly one possible such extension, the agent adopts this extension as its new SharedPlan; otherwise, it may ask a clarification question. A similar story can be told if the user does not actually perform *A*, but only proposes doing *A* (as in, "Let's do *A*").

We exploit three properties of the collaborative setting to make this use of plan recognition tractable. The first property is the *focus of attention*. When the user says, "Let's work on email," he is not only proposing a certain action be performed, he is also establishing a new context which restricts the interpretation of future utterances and actions. The full implications of focus of attention are beyond the scope of this paper (see Grosz and Sidner, 1990); in this work we use the weaker notion of the "focus act"<sup>3</sup> to limit the search required for plan recognition.

A second property of collaboration we exploit is that the processes of developing, communicating about, and executing plans are interleaved. Consequently, both the input and output of the plan recognizer are partially elaborated hierarchical plans. Unlike the "classical" definition of plan recognition (e.g., Kautz and Allen, 1986), which requires reasoning over complete and correct plans, our recognizer is only required to incrementally extend a given plan.

Third, it is quite natural during collaboration to ask for clarification, either because of inherent ambiguity, or simply because the computation required to understand an observed or mentioned action is beyond a participant's abilities. We use clarification to ensure that the number of actions the plan recognizer must interpret will always be small.

## 2 Algorithms

This section presents our plan recognizer and describes how it is used in discourse interpretation. We begin by adopting a straightforward formalization of actions, plans, and recipes.

<sup>2</sup> If the agent knows that the message to Dan is in reaction to the message from Chuck, it can, for example, be more helpful a week later when the user asks, "Did I ever react to the message from Chuck?"

<sup>3</sup> The focus act is what is called the "discourse segment purpose" in SharedPlan theory (see Lochbaum, 1998). The theory also specifies the rules by which discourse segments (contexts) are pushed and popped.

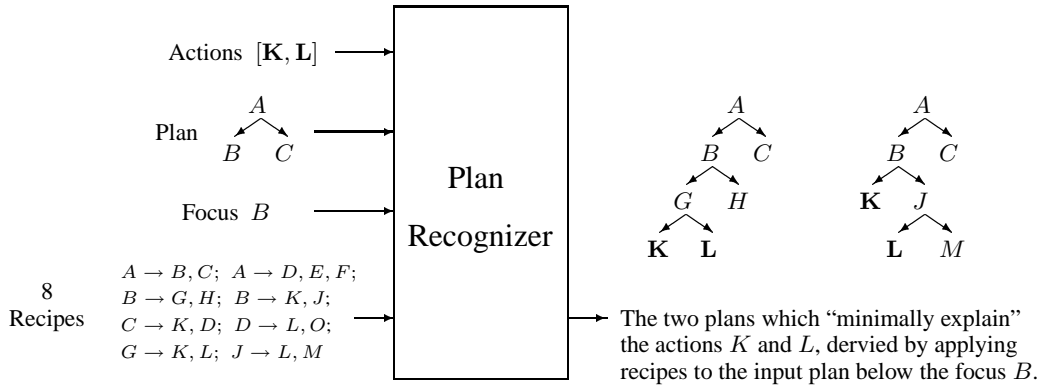

**Figure 2.** Simple example of inputs and outputs of plan recognition for collaboration

Let  $\mathcal{ACT}$  be a set of actions which includes primitive actions,  $\mathcal{PRIM} \subseteq \mathcal{ACT}$ , and “top level” actions,  $\mathcal{TOP} \subseteq \mathcal{ACT}$ , which might be done for no other purpose than themselves. Primitive actions can be executed directly, while non-primitive (abstract) actions are achieved indirectly by achieving other actions. We assume a predicate  $\text{DONE?}(A)$  which returns true if  $A$  has been achieved or executed. In our implementation, each action also has an associated type, parameters, timestamp, and so on; but will not need to explicitly refer to these here.

Beliefs concerning hierarchical goal decomposition (such as found in a SharedPlan) are formalized as a tuple  $\langle \mathcal{A}, \mathcal{E}, \mathcal{C} \rangle$ , which we will simply call a “plan,” where  $\mathcal{A}$  is a set of actions,  $\mathcal{E}$  is a set of directed acyclic edges on  $\mathcal{A}$ , where the edge  $A_i \rightarrow A_j$  means that  $A_j$  is a step in achieving  $A_i$ , and where  $\mathcal{C}$  is a set of constraints.  $\mathcal{C}$  may include temporal ordering between actions in  $\mathcal{A}$ , as well as other logical relations among their parameters.<sup>4</sup> As shown in Figure 2, plans can be viewed as trees (with an associated set of constraints, not shown in diagrams).

For plan  $P = \langle \mathcal{A}, \mathcal{E}, \mathcal{C} \rangle$ , we define  $A_i \in P$  to mean  $A_i \in \mathcal{A}$ . Let  $\text{CONSISTENT?}(P)$  be a predicate which determines whether  $\mathcal{C}$  is satisfiable; and  $\text{REPLACE}(P, A_1, A_2)$  be a function which returns the (possibly inconsistent) plan resulting from replacing action  $A_1$  with action  $A_2$  in  $\mathcal{A}$ ,  $\mathcal{E}$ , and  $\mathcal{C}$ .

Recipes are methods for decomposing non-primitive actions into subgoals. We represent recipes as functions that map an action to a plan that achieves the action. Let  $\mathcal{RECIPE}$  be a set of recipes, where each recipe  $R_k$  is a function from a non-primitive action  $A_i$  to a plan  $\langle \mathcal{A}', \mathcal{E}', \mathcal{C}' \rangle$ , where  $A_i$  is in  $\mathcal{A}'$  and for every  $A_j \neq A_i$  in  $\mathcal{A}'$  there is an edge  $A_i \rightarrow A_j$  in  $\mathcal{E}'$  i.e., the  $A_j$  are the *steps* in recipe  $R_k$  for achieving  $A_i$ .<sup>5</sup> For convenience, we define a function  $\text{EXTEND}(P, R_k, A_i)$ , which returns the plan  $\langle \mathcal{A} \cup \mathcal{A}', \mathcal{E} \cup \mathcal{E}', \mathcal{C} \cup \mathcal{C}' \rangle$ .

## 2.1 Plan Recognition

As shown in Figure 2, the inputs to our plan recognizer are a sequence of actions  $[A_1, \dots, A_n]$ , a plan  $P = \langle \mathcal{A}, \mathcal{E}, \mathcal{C} \rangle$ , a focus action  $f \in P$ , and a recipe library  $\mathcal{R} \subseteq \mathcal{RECIPE}$ . The output

<sup>4</sup> As shown in line 16 of Figure 1(c), our implementation allows recipes with optional steps, but for simplicity we do not include this feature in our formulation here.

<sup>5</sup>  $R_k$  may return the plan  $\langle \{A_i\}, \emptyset, \emptyset \rangle$  if it is not applicable to  $A_i$ .

<p style="text-align: center;"><u>(a) Plan recognition.</u></p> <pre> RECOGNIZE(<math>[A_1, \dots, A_n], P, f, \mathcal{R}</math>) <math>\equiv</math> <math>\mathcal{E}\mathcal{X}\mathcal{P}\mathcal{L} \leftarrow \emptyset, \mathcal{Q} \leftarrow \emptyset</math> <b>if</b> <math>P = \langle \emptyset, \emptyset, \emptyset \rangle</math>   <b>foreach</b> <math>T_i \in \mathcal{T}\mathcal{O}\mathcal{P}</math>     add <math>\langle [A_1, \dots, A_n], \langle \{T_i\}, \emptyset, \emptyset, T_i \rangle</math> to <math>\mathcal{Q}</math>   <b>else foreach</b> <math>g_i \in \text{FRINGE}(P, f)</math>     add <math>\langle [A_1, \dots, A_n], P, g_i \rangle</math> to <math>\mathcal{Q}</math> <b>until</b> <math>\mathcal{Q} = \emptyset</math>   remove <math>\langle [A'_1, \dots, A'_{n'}], P', act \rangle</math> from <math>\mathcal{Q}</math>   <math>P'' \leftarrow \text{REPLACE}(P', act, A'_1)</math>   <b>if</b> <math>\text{CONSISTENT?}(P'')</math>     <b>if</b> <math>n' = 1</math> add <math>P''</math> to <math>\mathcal{E}\mathcal{X}\mathcal{P}\mathcal{L}</math>     <b>else foreach</b> <math>g_i \in \text{FRINGE}(P'', f)</math>       add <math>\langle [A'_2, \dots, A'_{n'}], P'', g_i \rangle</math> to <math>\mathcal{Q}</math>   <b>if</b> <math>act \notin \mathcal{P}\mathcal{R}\mathcal{I}\mathcal{M}</math>     <b>foreach</b> recipe <math>R_k \in \mathcal{R}</math>       <math>P''' \leftarrow \text{EXTEND}(P', R_k, act)</math>       <b>foreach</b> <math>s_j</math>, where <math>act \rightarrow s_j \in P'''</math>         add <math>\langle [A'_1, \dots, A'_{n'}], P''', s_j \rangle</math> to <math>\mathcal{Q}</math>   <b>return</b> <math>\mathcal{E}\mathcal{X}\mathcal{P}\mathcal{L}</math> </pre>	<p style="text-align: center;"><u>(b) Focus, ambiguity and clarification.</u></p> <pre> <math>plan \leftarrow \langle \emptyset, \emptyset, \emptyset \rangle, focus \leftarrow null, acts \leftarrow []</math> <b>repeat</b>   wait for next input action <math>A_i</math>,   <b>if</b> <math>\text{DONE?}(\text{root of } plan)</math>     <math>plan \leftarrow \langle \emptyset, \emptyset, \emptyset \rangle, focus \leftarrow null</math>   add <math>A_i</math> to <math>acts</math>   <math>pick \leftarrow null</math>   <math>\mathcal{E}\mathcal{X}\mathcal{P}\mathcal{L} \leftarrow \text{RECOGNIZE}(acts, plan, focus, \mathcal{R})</math>   <b>if</b> <math>\mathcal{E}\mathcal{X}\mathcal{P}\mathcal{L} = \emptyset</math>     set <math>focus</math> to root of <math>plan</math>     <math>\mathcal{E}\mathcal{X}\mathcal{P}\mathcal{L} \leftarrow \text{RECOGNIZE}(acts, plan, focus, \mathcal{R})</math>   <b>if</b> <math> \mathcal{E}\mathcal{X}\mathcal{P}\mathcal{L}  = 1</math>     remove <math>pick</math> from <math>\mathcal{E}\mathcal{X}\mathcal{P}\mathcal{L}</math>   <b>else if</b> <math>\mathcal{E}\mathcal{X}\mathcal{P}\mathcal{L} = \emptyset</math> or <math> acts  &gt; MaxWait</math>     <math>pick \leftarrow \text{CLARIFY}(\mathcal{E}\mathcal{X}\mathcal{P}\mathcal{L})</math>   <b>if</b> <math>pick \neq null</math>     <math>plan \leftarrow pick</math>     <math>focus \leftarrow \text{UPDATEFOCUS}(plan, A_i)</math>     <math>acts \leftarrow []</math> </pre>
---	--

**Figure 3.** Pseudo-code for algorithms.

of the recognizer is a (possibly empty) set of extensions of  $P$  which “minimally explain” the input actions by applying recipes “below” the focus. More formally, each output plan,  $P' = \langle \mathcal{A}', \mathcal{E}', C' \rangle$ , has the following properties:

1.  $\{A_1, \dots, A_n\} \subseteq A'$ ,
2. every action in  $(\mathcal{A}' - \mathcal{A})$  is reachable in  $\mathcal{E}'$  from  $f$ ,
3.  $P'$  can be derived from  $P$  by a composition of calls to  $\text{EXTEND}(\dots, R_k, \dots)$ , where  $R_k \in \mathcal{R}$ , and  $\text{REPLACE}(\dots, \dots, A_k)$ , where  $A_k \in \{A_1, \dots, A_n\}$ , and
4. no smaller plan  $\langle \mathcal{A}'', \mathcal{E}'', C'' \rangle$ , and  $A'' \subseteq A', E'' \subseteq E', C'' \subseteq C'$ , satisfies these properties.

Figure 3(a) shows pseudo-code for a simple plan recognizer that performs an exhaustive search of all possible ways of extending the input plan to explain the input actions. To understand the search space, consider how the input plan might be extended to include the first input action  $A_1$ . To explain  $A_1$ , the recognizer must apply some sequence of recipes  $R_1, \dots, R_k$  to the input plan  $P$  and then replace an action in the resulting plan with  $A_1$ .<sup>6</sup> The first recipe  $R_1$  must be applied to a non-primitive action  $g_o$  in plan  $P$  that has not yet been expanded. Additionally,  $g_o$  must be beneath the focus  $act$   $f$  in the subgoal structure of  $P$ . The function  $\text{FRINGE}(P, f)$  returns the set of actions in  $P$  reachable from  $f$  which are leaves of the plan tree and are not  $\text{DONE?}$ .

After applying recipe  $R_1$  to an action  $g_o$  on the fringe of  $P$ , the recognizer only considers applying a second recipe,  $R_2$ , to  $g_o$ 's subgoals, i.e., the steps added by  $R_1$ . This is justified because a plan can never be *minimally* extended to explain one action by applying recipes to

<sup>6</sup> The recipe sequence can have length zero, i.e., we replace an action already in the plan with  $A_1$ .

multiple actions in the original plan. Similarly, the recognizer need only consider applying recipe  $R_3$  to steps added by  $R_2$  and, generally, only considers applying  $R_i$  to the steps added by  $R_{i-1}$ . It follows that the size of the search space to explain one action is bounded by  $F(R \times S)^L$ , where  $S$  is the maximum number of steps in a recipe,  $R$  is the maximum number of recipes applicable to an action,  $F$  is the number of actions on the fringe of  $P$ , and  $L$  is the length of the longest sequence of recipes  $R_1, \dots, R_L$  the algorithm must consider.<sup>7</sup>

When the recognizer finds a plan  $P'$  which explains  $A_1$  but there are more input actions to explain, it repeats the entire process to find all ways of extending  $P'$  to also explain action  $A_2$ , and so on until it has found all plans that minimally explain every input action. Since the algorithm recurses for each input action, its worst-case complexity is  $\mathbf{O}((F'(R \times S)^L)^N)$ , where  $F'$  is the maximum fringe size at any point and  $N$  is the number of input actions.

How does this compare to the general case? In the general case, the recognizer needs to search the entire plan space, because its output plans must contain no non-primitive steps that have not been decomposed. Let  $d$  be the depth of the deepest possible plan. Note that  $d \geq L$ , because if  $L$  recipes can be applied to explain a single action, then there must be a plan of at least depth  $L$ . The total number of plans that have to be searched is then  $\mathbf{O}((R^S)^d)$ . Thus if the number of input actions is small, the collaborative plan recognition problem is significantly more tractable than the general plan recognition problem. We guarantee that the number of input actions will be small with a policy that asks for clarification whenever the number of unexplained actions a threshold (described in next section).

## 2.2 Focus, Ambiguity and Clarification

We now discuss how to incorporate plan recognition into a collaborative agent (summarized in Figure 3(b)). It is beyond the scope of this paper to present the full SharedPlan discourse interpretation algorithm Lochbaum (1998) used in Collagen. Instead, we concentrate on the role of the focus of attention and what to do when the recognizer returns multiple explanations.<sup>8</sup>

First, consider the focus of attention. In natural dialogue, people use context to help understand otherwise ambiguous statements. People do not typically even think about all possible interpretations of a potentially ambiguous phrase, such as “Let’s save it”, if there is an obvious interpretation that makes sense given what was just said. Analogously, we use the focus act to restrict the search space of our plan recognizer. Only if the recognizer fails to find any explanations using the current focus do we expand the context; we do so by setting the focus to the root of the current plan and calling the recognizer again. The function `UPDATEFOCUS(plan, act)` in Figure 3(b) returns *act* if *act* is not DONE?; otherwise *act*’s nearest ancestor in the plan that is not DONE?. Thus, the focus is in general set at the lowest-level goal which is not yet achieved, but includes the last observed or mentioned act.

Of course, the focus of attention does not guarantee a unique explanation. When ambiguity arises, we choose between two options: either wait or ask for clarification. A reason to wait is that

<sup>7</sup> In general, there might not be a bound on  $L$  due to cycles in the recipe set. In practice, we halt search whenever a cycle is encountered. For simplicity, here we assume that the recipe library is acyclic (as in Kautz and Allen, 1986).

<sup>8</sup> There are also strategies in Collagen, not described here, for when the recognizer returns no explanations as well as methods for clarification of ambiguity between starting a new top level goal vs. working on optional steps of the current recipe.

future actions might resolve the ambiguity. A reason to ask now is that a collaborative system can be much more helpful when it knows what the user is doing. We believe it will be very difficult, in general, to compute the precise utility of asking for clarification. Instead, we use a simple heuristic: we ask for clarification as soon as there are *MaxWait* or more unexplained actions, where *MaxWait* is a small integer, currently set to 2.

We now briefly discuss how to manage a clarification sub-dialogue. Our collaborative agent first asks the user about the purpose of his most recent action, such as in lines 22–24 in Figure 1(c). If ambiguity remains, the agent then asks about the purpose of other actions in the user’s plan which would disambiguate intermediate recipes. In general the agent can pursue a variety of clarification strategies, including potentially lengthy dialogues in which the agent asks the user many simple questions, brief dialogues which require the user to choose a possible explanation from the agent’s current hypotheses, and a mixture of the two. At present, our agent engages in the potentially lengthy dialogues, but we intend to expand its repertoire to include other strategies.

### 2.3 Preliminary Evaluation

We have implemented the plan recognizer described above and integrated it into Collagen. The addition of plan recognition significantly reduced the amount of communication required of the user in typical scenarios. Our subjective impression was that this led to a much more natural collaboration, because the eliminated utterances were those that seemed most unnatural to a human.

In an initial attempt to quantify the impact of plan recognition, we have run some randomized experiments in the Lotus eSuite™ email domain. This recipe library contains 31 recipes, 32 primitive actions, and 19 non-primitive actions. In each trial, we randomly instantiated a plan and simulated a user executing it. Without recognition, the user must communicate every non-primitive action (goal) in the current plan. With recognition, our simulated user never volunteers information; it only performs primitive actions and answers clarification questions from the agent. Based on 100 random samples, we found that, without recognition, the user has to communicate, on average, about 4.4 times per plan. With recognition (and *MaxWait* = 2) the user only has to answer, on average, about 1.2 clarification questions per plan. The recognizer took an average of .94 CPU seconds to process each action. These results, however, convey only a general sense of how plan recognition can enhance collaboration, since the performance of the recognizer is very sensitive to the structure of the recipe library.

## 3 Related Work

The dominant framework for plan recognition research has been “keyhole” recognition, in which the observed actor is unaware of or indifferent to the observer (e.g., Kautz and Allen, 1986). Our recognizer takes two inputs that a keyhole recognizer does not: a partially elaborated plan and a focus act. These additional inputs simplify the plan recognition task because the recognizer must only extend the input plan, by applying recipes below the focus, just enough to explain the input actions. In the collaborative setting, the role of plan recognition is not to cleverly deduce an actor’s plan, but rather to allow collaborators to communicate more naturally and efficiently.

In the proliferation of recent work on plan recognition, researchers have addressed various limitations of the keyhole framework. We now discuss a variety of these approaches and illustrate how their settings and resulting techniques differ from our own.

Vilain (1990) presented a plan recognizer that runs in polynomial time. However, it only recognizes top level goals which is not sufficient for our purposes, and can only achieve polynomial time if the steps in the recipes are totally ordered, which is too restrictive for our domains. We believe Vilain's or other's fast recognition algorithms could be adapted to our formulation.

Lochbaum (1991) presented a plan recognition algorithm based on the SharedPlan model of collaboration. Her plan recognizer does not chain recipes together, as our does, and thus performs only "one level deep" recognition. It does, however, make use of a wider range of relations by which actions contribute to goals than we do.

Plan recognition has also been studied within a collaborative setting in which each participant works on their own plan but pools information and coordinates actions with others (e.g., Guinn, 1996, Smith et al., 1992). In particular, this work explores the opportunity for plan recognition when a participant announces that one of their goals has failed.

Our work is close in spirit to research on plan recognition for cooperative dialogues. Our use of context to narrow the scope of plan recognition resembles Carberry's (1990) focusing heuristics. Much work on cooperative response generation addresses the listener's need to know only enough of the speaker's plan to answer her questions adequately (e.g., Ardissono and Sestero, 1996). In contrast, we concentrate on a collaborative setting in which a joint plan is maintained by all collaborators and there is a shared artifact that all participants can interact with. A related distinction concerns ambiguity. The primary source of ambiguity in the cooperative response generation work resides in determining the user's top level goal (e.g., does the student want to take the course for credit or as an audit— see Lambert and Carberry (1991)). In our work, ambiguity arises because there are multiple ways of connecting actions to known higher level goals.

A variety of strategies for reducing ambiguity for plan recognition have been proposed. These include adopting the worst possible explanation for the observer in adversarial settings (e.g., Tambe and Rosenbloom, 1995), and assuming the observed person is doing what an expert system would suggest in a medical assistance domain (e.g., Gertner and Webber, 1996). In our collaborative setting, we use the focus of attention to reduce ambiguity, but failing this, we believe it often best just to ask the person what they are doing.

Probabilistic approaches to plan recognition (e.g., Bauer et al., 1993) would likely be effective and beneficial in the context of collaboration. However, we do not believe that probabilistic reasoning will eliminate either ambiguity or the need for clarification in human-computer collaboration because both seem fundamental to human-human collaboration.

Previous work has considered how to recognize the plans of someone who is performing more than one task at a time (e.g., Kautz and Allen, 1986, Lesh and Etzioni, 1995). We believe that in a collaborative setting, working on many tasks in parallel requires a great deal of communication and thus extending Collagen to handle simultaneous tasks primarily requires extensions to the discourse interpretation rather than the plan recognition component.

Plan recognition has often been proposed for improving user interfaces or to facilitate intelligent user help (e.g., Goodman and Litman, 1990, Lesh and Etzioni, 1995). Typically, the computer watches the user "over the shoulder" and jumps in with advice or assistance when the recognizer deduces the user's goals (e.g., Wilensky et al., 1988). This approach does not view human-computer interaction as collaboration, in which all participants are committed to maintaining mutual understanding of the common goals. Instead, it makes the (to us) implausible assumption that it is possible to infer the user's goals and plans by observing only primitive interface actions and to choose appropriate assistance without any mutual understanding.

## 4 Conclusion

Human-computer collaboration is a fruitful application for plan recognition because all participants are committed to maintaining a mutual understanding of the goals and actions to be performed. The question isn't whether the software agent will know the user's plan, but how the agent and the user can best communicate their intentions to each other. We have shown that plan recognition can allow more efficient and natural communication between collaborators, and can do so with relatively modest computation effort.

## References

- Ardissono, L., and Sestero, D. (1996). Using dynamic user models in the recognition of the plans of the user. In *User Modeling and User Adapted Interaction*, volume 2, 157–190.
- Bauer, M., Biundo, S., Dengler, D., Kohler, J., and G., P. (1993). PHI—a logic-based tool for intelligent help systems. In *Proc. 13th Int. Joint Conf. AI*.
- Carberry, S. (1990). Incorporating default inferences into plan recognition. In *Proc. 8th Nat. Conf. AI*, volume 1, 471–8.
- Ferguson, G., and Allen, J. (1998). Trips: An integrated intelligent problem-solving assistant. In *Proc. 15th Nat. Conf. AI*, 567–572.
- Gertner, A., and Webber, B. (1996). A bias towards relevance: Recognizing plans where goal minimization fails. In *Proc. 13th Nat. Conf. AI*, 1133–1138.
- Goodman, B., and Litman, D. (1990). Plan recognition for intelligent interfaces. In *Proc. 6th IEEE Conf. AI Applications*.
- Grosz, B. J., and Kraus, S. (1996). Collaborative plans for complex group action. *Artificial Intelligence* 86(2):269–357.
- Grosz, B. J., and Sidner, C. L. (1990). Plans for discourse. In Cohen, P. R., Morgan, J. L., and Pollack, M. E., eds., *Intentions and Communication*. Cambridge, MA: MIT Press. 417–444.
- Guinn, C. I. (1996). Mechanisms for dynamically changing initiative in human-computer collaborative discourse. In *Human Interaction with Complex Systems Symposium*.
- Kautz, H., and Allen, J. (1986). Generalized plan recognition. In *Proc. 5th Nat. Conf. AI*, 32–37.
- Lambert, L., and Carberry, S. (1991). A tripartite plan-based model of dialogue. In *Proc. 29th Annual Meeting of the ACL*, 47–54.
- Lesh, N., and Etzioni, O. (1995). A sound and fast goal recognizer. In *Proc. 14th Int. Joint Conf. AI*, 1704–1710.
- Lochbaum, K. E. (1991). An algorithm for plan recognition in collaborative discourse. In *Proc. 29th Annual Meeting of the ACL*.
- Lochbaum, K. E. (1998). A collaborative planning model of intentional structure. *Computational Linguistics* 24(4).
- Rich, C., and Sidner, C. (1998). COLLAGEN: A collaboration manager for software interface agents. *User Modeling and User-Adapted Interaction* 8(3/4):315–350.
- Rickel, J., and Johnson, W. L. (1998). Animated agents for procedural training in virtual reality: Perception, cognition, and motor control. *to appear in Applied Artificial Intelligence*.
- Smith, R. W., Hipp, D. R., and Biermann, A. W. (1992). A dialog control algorithm and its performance. In *Third Conference on Applied Natural Language Processing*.
- Tambe, M., and Rosenbloom, P. (1995). RESC: An approach for real-time, dynamic agent-tracking. In *Proc. 14th Int. Joint Conf. AI*, 103–110.
- Vilain, M. (1990). Getting serious about parsing plans: A grammatical analysis of plan recognition. In *Proc. 8th Nat. Conf. AI*, 190–197.
- Wilensky, R., Chin, D., Luria, M., Martin, J., Mayfield, J., and Wu, D. (1988). The Berkeley UNIX Consultant project. *Computational Linguistics* 14(4):35–84.