

# Application Performance in the QLinux Multimedia Operating System \*

Vijay Sundaram

Abhishek Chandra

Pawan Goyal†‡

Prashant Shenoy

Jasleen Sahni‡

Harrick Vin‡

Department of Computer Science  
University of Massachusetts  
Amherst, MA 01003  
{vijay,abhishek,shenoy}@cs.umass.edu

† Ensim Corporation  
1215 Terra Bella Ave  
Mountain View, CA 94043  
goyal@ensim.com

‡ Department of Computer Sciences  
University of Texas  
Austin, TX 78712  
{jks,vin}@cs.utexas.edu

## ABSTRACT

*In this paper, we argue that conventional operating systems need to be enhanced with predictable resource management mechanisms to meet the diverse performance requirements of emerging multimedia and web applications. We present QLinux—a multimedia operating system based on the Linux kernel that meets this requirement. QLinux employs hierarchical schedulers for fair, predictable allocation of processor, disk and network bandwidth, and accounting mechanisms for appropriate charging of resource usage. We experimentally evaluate the efficacy of these mechanisms using benchmarks and real-world applications. Our experimental results show that (i) emerging applications can indeed benefit from predictable allocation of resources, and (ii) the overheads imposed by the resource allocation mechanisms in QLinux are small. For instance, we show that the QLinux CPU scheduler can provide predictable performance guarantees to applications such as web servers and MPEG players, albeit at the expense of increasing the scheduling overhead. We conclude from our experiments that the benefits due to the resource management mechanisms in QLinux outweigh their increased overheads, making them a practical choice for conventional operating systems.*

## 1. Introduction

Recent advances in computing and communication technologies have led to the emergence of a wide variety of applications with diverse performance requirements. Today's general purpose operating systems are required to support a mix of (i) conventional best-effort applications that desire low average response times but no absolute performance guarantees, (ii) throughput-intensive applications that desire high average throughput, and (iii) soft real-time applications that require performance guarantees from the operating system. To illustrate, PCs in office environments run a mix of word processors, spreadsheets, streaming media players and large compilation jobs, while large-scale servers run a mix of network file

\* This research was supported in part by a NSF Career award CCR-9984030, NSF grants ANI 9977635, CDA-9502639, Intel, Sprint, and the University of Massachusetts.

Permission to make digital or hard copies of all or part of this work for personal or classroom use is granted without fee provided that copies are not made or distributed for profit or commercial advantage and that copies bear this notice and the full citation on the first page. To copy otherwise, to republish, to post on servers or to redistribute to lists, requires prior specific permission and/or a fee.

ACM Multimedia '00 Los Angeles, CA  
Copyright 2000 ACM 0-89791-88-6/97/05 ..\$5.00

services, web services, database applications and streaming media servers.

Whereas less demanding application mixes can be easily handled by a conventional best-effort operating system running on a fast processor, studies have shown that such operating systems are grossly inadequate for meeting the diverse requirements imposed by demanding application mixes [13, 15]. To illustrate, conventional operating systems running on even the fastest processors today are unable to provide jitter-free playback of full-motion MPEG-2 video in the presence of other applications such as long-running compile tasks. The primary reason for this inadequacy is the lack of service differentiation among applications—such operating systems provide a single class of best-effort service to all applications regardless of their actual performance requirements.<sup>1</sup> Moreover, special-purpose operating systems designed for a particular application class (e.g., real-time operating systems [12, 24]) are typically unable or inefficient at handling other classes of applications. This necessitates the design of an operating system that (i) multiplexes its resources among applications in a predictable manner, and (ii) uses service differentiation to meet the performance requirements of individual applications.

The QLinux operating system that we have developed meets these requirements by enhancing the standard Linux operating system with quality of service support. To do so, QLinux employs schedulers that can allocate resources to individual applications as well as application classes in a predictable manner. These schedulers are hierarchical—they support class-specific schedulers that schedule requests based on the performance requirements of that class (and thereby provide service differentiation across application classes). Specifically, QLinux employs four key components: (i) hierarchical start-time fair queueing (H-SFQ) CPU scheduler that allocates CPU bandwidth fairly among application classes [7], (ii) hierarchical start-time fair queueing (H-SFQ) packet scheduler that can fairly allocate network interface bandwidth to various applications [8], (iii) Cello disk scheduler that can support disk requests with diverse performance requirements [17], and (iv) lazy receiver processing for appropriate accounting of protocol processing overheads [6]. Figure 1 illustrates these components. We have implemented these components into QLinux and have made the source code freely available to the research community.<sup>2</sup>

<sup>1</sup>Rather than reduce the processor shares of all applications equally, an operating system that provides service differentiation might reduce the fraction of the CPU bandwidth allocated to best-effort compile jobs and thereby reduce the jitter in soft real-time video playback.

<sup>2</sup>Source code and documentation for QLinux is available from <http://www.cs.umass.edu/~lass/software/qlinux>.

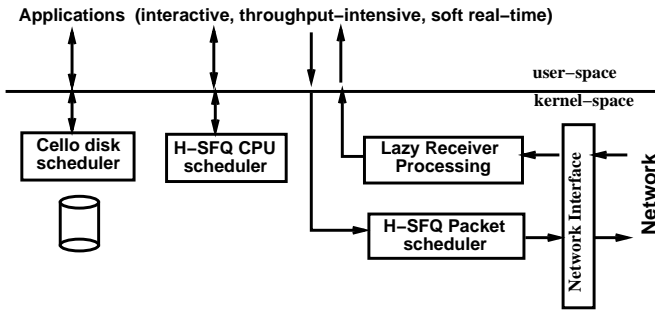

Figure 1: Key components of QLinux.

In this paper, we make four key contributions. First, we show how to synthesize several recent innovations in OS resource management into a seamless multimedia operating system. Second, we consider several real-world applications and application scenarios and demonstrate that these resource management techniques enable QLinux to provide benefits such as predictable performance, application isolation and fair resource allocation. For instance, we show that QLinux enables a streaming media server to stream MPEG-1 files at their real-time rates regardless of the background load. Third, we show that existing/legacy applications can also benefit from these features without any modifications whatsoever to the application source code. Finally, we show that the implementation overheads of these sophisticated resource management techniques are small, making them a practical choice for general-purpose operating systems. For instance, we show that the context switch overhead due to the H-SFQ CPU scheduler increases from  $1 \mu\text{s}$  to  $4 \mu\text{s}$ , but the increased overhead is still substantially smaller than the quantum duration. Based on these results, we argue that conventional operating systems should be enhanced with such resource management mechanisms so as to meet the needs of emerging applications as well as existing and legacy applications.

The rest of this paper is structured as follows. Section 2 discusses the principles underlying the design of QLinux and briefly describes each component employed by QLinux. Section 3 presents the results of our experimental evaluation. Section 4 discusses related work, and finally, Section 5 presents some concluding remarks.

## 2. QLinux Philosophy and Overview

In this section, we first present the principles underlying the design and implementation of QLinux. We then briefly describe each resource management component employed by QLinux (these mechanisms are described in detail elsewhere [6, 7, 8, 17]).

### 2.1 QLinux Design Principles

The design and implementation of QLinux is based on the following principles:

- *Support for Multiple Service Classes:* Today’s general purpose computing environments consist of a heterogeneous mix of applications with different performance requirements. As argued in Section 1, operating systems that provide a single class of service to all applications are inadequate for handling such diverse application mixes. To efficiently support such mixes, an operating system should *support multiple classes of service and align the service provided within each class with application needs*. For instance, an operating system

may support three classes of service—interactive, throughput-intensive and soft real-time—and treat applications within each class differently (interactive applications are provided low average response times, real-time applications are provided performance guarantees, and throughput-intensive applications are provided high aggregate throughput). Other operating systems such as Nemesis [16] have also espoused such a *multi-service* approach to operating system design.

- *Predictable resource allocation:* A multi-service operating system requires mechanisms that can multiplex its resources among applications in a predictable manner. Many operating systems (e.g., Solaris, UNIX SVR4) support multiple application classes using strict priority across classes. Studies have shown that such an approach can induce starvation in lower priority tasks even for common application mixes [13]. For instance, it has been shown that running a compute-intensive MPEG decoder in the highest priority real-time class on Solaris can cause even kernel tasks (which run at a lower priority) to starve, causing the entire system to “freeze” [13]. One approach to alleviate the starvation problem is to use dynamic priorities. Whereas the design of dynamic priority mechanisms for homogeneous workloads is easy, the design of such techniques for heterogeneous workloads is challenging. Consequently, QLinux advocates rate-based mechanisms over priority-based mechanisms for predictable resource allocation. Rate-based techniques allow a weight to be assigned to individual applications and/or application classes and allocate resources in proportion to these weights. Thus, an application with weight  $w_i$  is allocated  $\frac{w_i}{\sum_j w_j}$  fraction of the resource.<sup>3</sup> Observe that, rate-based allocation techniques are distinct from static partitioning of resources—they can dynamically reallocate resources unused by an application to other applications, and thereby yield better resource utilization than static partitioning.
- *Service differentiation:* Since different application classes have different performance requirements, an operating system that supports multiple service classes should provide service differentiation by treating applications within each class differently. To do so, QLinux employs hierarchical schedulers that support multiple class-specific schedulers via a flexible multi-level scheduling structure. A hierarchical scheduler in QLinux allocates a certain fraction of the resource to each class-specific scheduler using rate-based mechanisms; class-specific schedulers, in turn, use their allocations to service requests using an appropriate scheduling algorithm. The flexibility of using a different class-specific scheduler for each class allows QLinux to tailor its service to the needs of individual applications. Moreover, the approach is extensible since it allows existing class-specific schedulers to be modified, or new schedulers to be added.
- *Support for legacy applications:* We believe that only those mechanisms that preserve compatibility with existing and legacy applications are likely to be adapted by mainstream op-

<sup>3</sup>Such a resource allocation mechanism performs relative allocations—the fraction allocated to an application depends on the weights assigned to other applications. Rate-based mechanisms that allocate resource in absolute terms have also been developed. Such mechanisms allow applications to be allocated an absolute fraction  $f_i$  ( $\sum f_i < 1$ ), or allocate  $x_i$  units every  $y_i$  units of time. We chose a relative allocation mechanism based on weights due to its simplicity.

erating systems in the near future. Hence, QLinux chooses an incremental approach to OS design. Each mechanism within QLinux is carefully designed to maintain full compatibility with existing applications at the binary level. We also decided that mere compatibility was not enough—we wanted existing applications to possibly benefit (but definitely not suffer) from the new resource allocation mechanisms in QLinux (although the degree to which they benefit would be less than new applications that are explicitly designed to take advantage of these features).

- *Proper accounting of resource usage:* An operating system that allocates resources in a predictable manner should employ mechanisms to accurately account and charge for resource usage. Whereas most operating systems employ mechanisms that can accurately track the amount of CPU bandwidth consumed by applications, resources consumed by kernel tasks are not accounted for in the same manner. For instance, many kernel tasks such as interrupt processing and network protocol processing occur asynchronously and get charged to the currently running process rather than the process that triggered these tasks. Other kernel tasks such as scheduling decisions or book-keeping operations are system-wide in scope in that they cannot be attributed to a particular process. Improper or inaccurate accounting of resource usage can cause the bandwidth allocated to an application to deviate significantly from its specified share. QLinux employs a two-pronged approach to deal with such accounting issues.

- It employs lazy receiver processing [6], a technique to ensure that network protocol processing overheads are charged to the appropriate process (rather than arbitrarily charging it to the currently running process). This is achieved by deferring protocol processing from packet arrival time to the time a process attempts to receive the data from a network socket.
- Since lazy receiver processing accounts only for protocol processing overheads, other mechanisms are required to account for kernel tasks such as interrupt processing and book-keeping operations. To address this limitation, QLinux employs a CPU scheduler that provides predictable performance even in the presence of fluctuating processor bandwidth. Specifically, the fairness guarantees provided by the CPU scheduler hold even when a varying amount of CPU bandwidth is used up by kernel tasks, thereby resulting in more predictable allocation [8].

Together, these two techniques ensure accurate accounting and predictable allocation of resources in QLinux.

Next, we describe the four key components of QLinux.

## 2.2 Hierarchical Start-time Fair Queueing (H-SFQ) CPU Scheduler

Hierarchical start-time fair queueing (H-SFQ) is a hierarchical CPU scheduler that fairly allocates processor bandwidth to different application classes and employs class-specific schedulers to manage requests within each class [7]. The scheduler uses a tree-like structure to describe its scheduling hierarchy (see Figure 2). Each process or thread in the system belongs to exactly one leaf node. A leaf node is an aggregation of threads and represents an *application class* in the system. Each non-leaf node is an aggregation of application classes. Each node in the tree has a weight

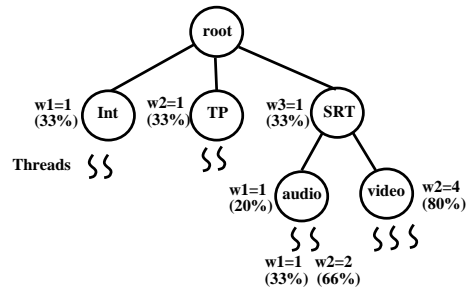

Figure 2: A sample hierarchy employed by the H-SFQ CPU scheduler. The figure shows three classes—interactive, throughput-intensive and soft real-time—with equal share of the processor bandwidth. The bandwidth within the soft real-time class is further partitioned among the audio and video classes in the proportion 1:4. Individual threads can also be assigned weights, assuming the leaf node scheduler supports rate-based allocation.

that determines the fraction of its parent’s bandwidth that should be allocated to it. Thus, if  $w_1, w_2, \dots, w_n$  denote the weights on the  $n$  children of a node, and if  $B$  denotes the processor bandwidth allocated to the node, then the bandwidth received by each child node  $i$  is given by

$$B_i = \left( \frac{w_i}{\sum_j w_j} \right) * B$$

Each node is also associated with a scheduler. Whereas the scheduler of the leaf node schedules all threads belonging to the leaf, the scheduler of an intermediate node schedules all its children. Scheduling of threads occurs hierarchically in H-SFQ: the root node schedules one of its child nodes; the child node, in turn, schedules one of its children until a leaf node schedules a thread for execution. Any class-specific scheduler may be employed to schedule a leaf node. For instance, the standard time-sharing scheduler could be employed for scheduling threads in the interactive class, whereas the earliest deadline first (EDF) scheduler could be used to schedule soft real-time tasks. H-SFQ employs start-time fair queueing (SFQ) as the scheduling algorithm for a non-leaf node. SFQ is a rate-based scheduler that allocates weighted fair shares—bandwidth allocated to each child node is in proportion to its weight. Bandwidth unused by a node is redistributed to other nodes according to their weights. In addition to rate-based allocation, SFQ has the following properties: (i) it achieves fair allocation of CPU bandwidth regardless of variation in available capacity, (ii) it does not require the length of the quantum to be known a priori (and hence, can be used in general-purpose environments where threads may block for I/O before their quantum expires), and (iii) SFQ provides provable guarantees on fairness, delay, and throughput received by each thread in the system [7, 8].

H-SFQ replaces the standard time-sharing scheduler in QLinux. The default scheduling hierarchy in H-SFQ consists of a root node with a single child that uses the standard time-sharing scheduler to schedule threads. An application, by default, is assigned to the time-sharing scheduler, thereby allowing QLinux to mimic the behavior of standard Linux. The scheduling hierarchy can be modified dynamically at run-time by creating new nodes on the fly. Creating a new node involves specifying the parent node, a weight, and a scheduling algorithm, if the node is a leaf node (non-leaf nodes are scheduled using SFQ). QLinux allows processes and threads to

Table 1: System call interface supported by the H-SFQ CPU scheduler

System call	Purpose
hsfq_mknod	create a new node in the scheduling hierarchy
hsfq_rmnod	delete an existing node from the hierarchy
hsfq_join_nod	attach the current process to a leaf node
hsfq_move	move a process to a specified child node
hsfq_parse	parse a pathname in the scheduling hierarchy
hsfq_admin	administer a node (e.g., change weights)

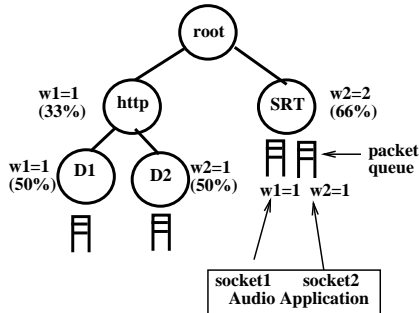

Figure 3: The H-SFQ network packet scheduler. The figure shows a sample scheduling hierarchy with two classes—http and soft real-time. The bandwidth within the http class is further partitioned among two web domains,  $D1$  and  $D2$ , in the ratio 1:1. Note that individual sockets can either share a queue or have a queue of their own. Since each queue has its own weight, in the latter case, bandwidth allocation can be controlled on a per-socket basis.

be assigned to a specific node at process/thread creation time; processes and threads can be moved from one leaf node to another at any time. Moreover, weights assigned to an application or a node in the scheduling hierarchy can be modified dynamically. QLinux employs a set of system calls to achieve these objectives (see Table 1). We have also implemented several utility programs to manipulate the scheduling hierarchy as well as individual applications within the hierarchy. These utilities allow existing/legacy applications to benefit from the features of H-SFQ since users can assign weights to applications without modifying the source code.

### 2.3 H-SFQ Packet Scheduler

An operating system employs a packet scheduler at each of its network interfaces to determine the order in which outgoing packets are transmitted. Traditionally, most operating systems have employed the FIFO scheduler to schedule outgoing packets. To better meet the needs of applications with different requirements, QLinux employs H-SFQ to schedule outgoing packets. As described in Section 2.2, H-SFQ can fairly allocate resource bandwidth among different application classes in a hierarchical manner. As in the case of CPU, the H-SFQ packet scheduler employs a multi-level tree-like scheduling structure to hierarchically allocate network interface bandwidth (see Figure 3). Each leaf node in the tree consists of one or more queues of outgoing network packets and any class-specific scheduler can be employed to schedule the transmission of packets from these queues; the default leaf scheduler is FIFO. A non-leaf node is scheduled using SFQ. Every node in the hierarchy

Table 2: System call interface supported by the H-SFQ packet scheduler

System call	Purpose
hsfq_qdisc_install	Install HSFQ queuing discipline at a network interface
hsfq_link_mknod	create a node in the scheduling hierarchy
hsfq_link_createq	create a packet queue
hsfq_link_attachq	attach a queue to a leaf node
hsfq_link_moveq	move a queue between schedulers
hsfq_link_rmnod	delete the specified node
hsfq_link_rmq	delete the specified queue
hsfq_link_modify	change the weight of a node/queue
hsfq_link_parsenode	parse a pathname in the scheduling hierarchy
hsfq_link_getroot	get the ID of the root node at a particular network interface
hsfq_link_status	display the scheduling tree
setsockopt	attach a socket to a queue

Table 3: System call interface supported by Cello

System call	Purpose
cello_open	Open a file and associate it with the specified class
cello_read	read data using an optional deadline
cello_write	write data using an optional deadline
cello_set_class	associate a class with a process
cello_admin	administer a class (e.g., specify weights)

is assigned a weight; H-SFQ allocates bandwidth to nodes in proportion to their weights. Bandwidth unused by a node is reallocated fairly among the nodes with pending packets, thereby improving overall utilization.

The H-SFQ packet scheduler in QLinux replaces the FIFO scheduler employed by Linux. The default scheduling hierarchy in H-SFQ is a root node with a single child that employs FIFO scheduling. Packets sent by applications are, by default, queued up at this node, enabling QLinux to emulate the behavior of Linux. As in the case of the CPU scheduler, the scheduling hierarchy can be modified by adding new nodes to the tree or deleting existing nodes. QLinux allows applications to be associated to a specific queue at a leaf node (via the `setsockopt` system call); this association can be done on a per-socket basis. Packet classifiers [19] are then employed to map each transmitted packet to the corresponding queue at a leaf node. Table 2 lists the system call interface exported by the packet scheduler to achieve these objectives. We are currently implementing utility programs using these system calls that will enable existing applications to benefit from these features without having to modify their source code.

### 2.4 Cello Disk Scheduler

Unlike disk scheduling algorithms such as SCAN that provide a best-effort service to disk requests, QLinux employs the Cello disk scheduling algorithm to support multiple application classes. Cello services disk requests using a two level scheduling algorithm, consisting of a class-independent scheduler and a set of class-specific

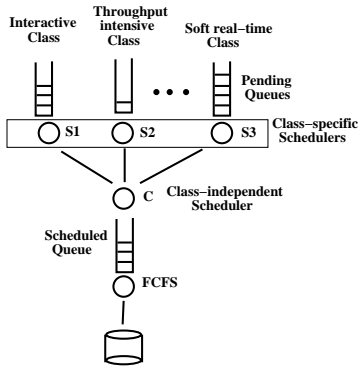

Figure 4: The Cello disk scheduling algorithm.

schedulers [17]. The class-independent scheduler is responsible for allocating disk bandwidth to classes based on their weights, whereas the class-specific schedulers use these allocations to schedule individual requests based on their requirements. Unlike pure rate-based schedulers that focus only on fair allocation of resources, Cello also takes disk seek and rotational latency overheads into account when making scheduling decisions (thereby improving disk throughput).

The implementation of Cello in QLinux supports three application classes—interactive, throughput-intensive and soft real-time. To do so, QLinux maintains three pending queues, one for each application class and a scheduled queue (see Figure 4). Newly arriving requests are queued up in the appropriate pending queue. They are eventually moved to the scheduled queue and dispatched to the disk in FIFO order. The class-independent scheduler determines *when* and *how many* requests to move from each class-specific pending queue to the scheduled queue, while the class-specific schedulers determine *where* to insert it into the scheduled queue. To maintain compatibility with Linux, Cello uses the interactive best-effort class as the default class to service disk requests. Applications can override this default by specifying a class for each file that is read or written. For the soft real-time class, an application must also specify a deadline with each read or write request. Table 3 lists the interface exported by Cello to achieve these objectives. Note that the current implementation of Cello supports bandwidth allocation only on a per-class basis; in the future, we plan to add support for bandwidth allocation on a per-application basis.

## 2.5 Lazy Receiver Processing

Consider the operation of a network subsystem within a typical operating system. When a packet arrives at a network interface card, it causes an interrupt. The OS then suspends the currently running process and invokes an interrupt service routine to process the packet. Typically this processing involves executing the protocols at the data link layer (e.g., ethernet), the network layer (IP), and the transport layer (TCP or UDP). Observe that, by using the CPU quantum of the suspended process to do protocol processing, these overheads get charged to this process rather than the process that will eventually receive the packet. Such accounting anomalies result in violation of performance guarantees provided to applications by a multimedia operating system, especially on servers running network applications (e.g., http servers). Lazy receiver processing (LRP) is a technique that overcomes this drawback [6]. LRP postpones protocol processing from packet arrival time to the time a

process actually receives data by reading it from a socket. Postponing protocol operations to socket read time enables the OS to charge these overheads to the process that actually receives the data. The key challenge in designing an LRP-based network subsystem is to ensure only those protocol operations are postponed that do not affect protocol performance or semantics. For instance, TCP performs asynchronous operations such as sending acknowledgements for received packets. Delaying acknowledgements can severely affect the throughput received by an application (since the window-based flow control mechanism in TCP won't permit the sender to send additional data without receiving acknowledgements). Since such asynchronous operations can not be postponed, LRP employs a special kernel thread for each application to perform these operations as and when required. The kernel thread executes independently of the application process and its CPU usage is charged to the parent process.

The implementation of LRP in QLinux employs a queue per socket in the data link layer and employs early demultiplexing of incoming packets—a technique that classifies packets into these queues immediately upon arrival. Thus, interrupt processing upon the arrival of a process only involves packet classification to the appropriate queue and does not involve any expensive protocol processing; these operations are deferred to socket read time. Special kernel threads are employed to handle asynchronous operations as well as to implement protocols such as ARP and ICMP that are not process-specific. Finally, observe that LRP is transparent to applications—no additional system calls are required to support it, nor do you need to modify applications.

## 3. Experimental Evaluation

In this section, we experimentally evaluate the performance of QLinux and compare it to vanilla Linux. In particular, we examine the efficacy of the resource allocation mechanisms within QLinux to (i) allocate resource bandwidth in a predictable manner, (ii) provide application isolation, (iii) support multiple traffic classes, and (iv) accurately account for resource usage. We use several real applications, benchmarks and micro-benchmarks for our experimental evaluation. In what follows, we first describe the test-bed for our experiments and then present the results of our experimental evaluation.

### 3.1 Experimental Setup

The test-bed for our experiments consists of a cluster of PC-based workstations. Each PC used in our experiments is a 350MHz Pentium II with 64MB RAM and runs RedHat Linux 6.1. Each PC is equipped with a 100 Mb/s 3-Com ethernet card (model 3c595); all machines are interconnected by a 100 Mb/s ethernet switch (model 3Com SuperStack II). The version of QLinux used in our experiments is based on the 2.2.0 Linux kernel; comparisons with vanilla Linux use the identical version of the kernel. All machines and the network are assumed to be lightly loaded during our experiments.

The workload for our experiments consists of a combination of real-world applications, benchmarks, and sample applications that we wrote to demonstrate specific features. These applications are as follows: (i) *Inf*: an application that executes an infinite loop and represents a simple compute-intensive best-effort application; (ii) *mpeg\_play*: the Berkeley software MPEG-1 decoder; represents a compute-intensive soft real-time application; (iii) *Apache web server* and *webclient*: a widely-used web server and a configurable client application that generates http requests at a specified rate; represents an I/O-intensive best-effort application; (iv) *Streaming media server*: a server that transmits (*streams*) MPEG-1 files over

the network using UDP; represents an I/O-intensive soft real-time application; (v) *Net\_inf*: an application that sends UDP data as fast as possible on a socket; represents an I/O-intensive best-effort application; (vi) *Dhrystone*: a compute-intensive benchmark for measuring integer CPU performance; (vii) *lmbench*: a comprehensive benchmark suite that measures various aspects of operating system performance such as context switching, memory, file I/O, networking, and cache performance.

In what follows, we present the results of our experimental evaluation using these applications and benchmarks. Since the code for the Cello disk scheduler was unstable at the time of writing, we have not included experimental results for Cello.

### 3.2 Supporting Multiple Application Classes using the H-SFQ CPU Scheduler

To demonstrate that the H-SFQ CPU scheduler can allocate CPU bandwidth to applications in proportion to their weights, we created two classes in the scheduling hierarchy and ran the *Inf* application in each class. We assigned different combination of weights to the two classes (e.g., 1:1, 1:2, 1:4) and measured the number of loops executed by *Inf* in each case. Figures 5(a) and (b) depict our results. Figure 5(a) shows the progress made by the two *Inf* applications for a specific weight assignment of 1:4. Figure 5(b) shows the number of iterations executed by the two processes at  $t=337$  seconds for different weight assignments. Together, the two figures show that each application gets processor bandwidth in proportion to its weight.

Next, we conducted an experiment to demonstrate the fair work-conserving nature of H-SFQ. Again, we created two application classes and gave them equal weights (1:1). The *Inf* application was run in each class and as expected each received 50% of the CPU bandwidth. At  $t=250$  seconds, we suspended one of the *Inf* processes. Since H-SFQ is work-conserving in nature, the scheduler reallocated bandwidth unused by the suspended processes to the running *Inf* process (causing its rate of progress to double). The suspended process was restarted at  $t=350$  seconds, causing the two processes to again receive bandwidth in the proportion 1:1. Figure 5(c) depicts this scenario by plotting the progress made by the continuously running *Inf* process. As shown, the process makes progress at twice the rate between  $250 \leq t < 350$  and receives its normal share in other time intervals.

We then conducted experiments to show that real-world applications also benefit from H-SFQ. To show that the CPU scheduler can effectively isolate applications from one another, we created two classes—soft real-time and best-effort—and assigned them equal weights. The best-effort leaf class was scheduled using the standard time sharing scheduler, while the soft real-time leaf class was scheduled using SFQ. We ran the Berkeley software MPEG decoder (*mpeg\_play*) in the soft real-time class and used it to decode a five minute long MPEG-1 clip with an average bit rate of 1.49 Mb/s. The *Dhrystone* benchmark constituted the load in the best-effort class. We increased the load in the best-effort class (by increasing the number of independent *Dhrystone* processes) and measured the CPU bandwidth received by the MPEG decoder in each case. We then repeated this experiment using vanilla Linux. Figure 6(a) plots our results. As shown in the figure, in case of QLinux, the CPU bandwidth received by the MPEG decoder was independent of the load in the best-effort classes. Since vanilla Linux employs a best-effort scheduler, all applications, including the MPEG decoder, are degraded equally as the load increases. This demonstrates that H-SFQ, in addition to proportionate allocation, can also isolate application classes from one another. To further demonstrate this behavior, we ran two Apache web servers in two different classes and gave them different weights. The *webclient* application

was used to send a large number of http requests to each web server and we measured the processor bandwidth received by each class. As shown in Figure 6(b), the H-SFQ scheduler allocates processor bandwidth to the two classes in proportion to their weights. These experiments demonstrate that QLinux can be employed for web hosting scenarios where multiple web domains are hosted from the same physical server. Each web domain can be allocated a certain fraction of the resources and can be effectively isolated from the load in other domains.

### 3.3 Supporting Multiple Traffic Classes Using the H-SFQ Packet Scheduler

To demonstrate that the H-SFQ packet scheduler can allocate network interface bandwidth to applications in proportion to their weights, we created two classes in the scheduling hierarchy and ran the *Net\_inf* application in each class. The UDP packets sent by *Net\_inf* were received as fast as possible by a receiver process running on a lightly loaded PC. We varied the weights assigned to the two classes and measured the number of packets sent by the two processes for different weight assignments. Figure 7(a) depicts the number of bytes received from each *Net\_inf* for one particular weight assignment (1:4). As expected, both classes receive bandwidth in proportion to their weights. To demonstrate that bandwidth received by a class is independent of the packet size, we repeated the experiment using different packet sizes for the two classes. Figure 7(b) shows that, despite using different packet sizes, the two classes again receive bandwidth in proportion to their weights.

To demonstrate that real-world applications also benefit from these features, we conducted an experiment with two classes—soft real-time and best-effort. The streaming media server was run in the soft real-time class and was used to stream a five minute long variable bit-rate MPEG-1 clip (average bit rate of the clip was 1.49 Mb/s). We ran an increasing number of *Net\_inf* applications in the best-effort class and measured their impact on the bandwidth received by the streaming media server. We then repeated this experiment on vanilla Linux. As shown in Figure 8, QLinux is able to effectively isolate the streaming media server from the best-effort class—the server is able to stream data at its real-time rate regardless of the best-effort load. Linux, on the other hand, is unable to provide this isolation—increasing the best-effort load reduces the bandwidth received by the streaming media server and also increases the amount of packet loss incurred by all applications.

### 3.4 Combined Impact of H-SFQ CPU and Packet Schedulers

To demonstrate the combined benefits of the CPU and packet schedulers, we considered a scenario consisting of a loaded web server and several I/O intensive applications. We created two classes in the CPU and packet scheduler hierarchies. We ran a simulated web server in one CPU/packet scheduler class and ran all the I/O-intensive *Net\_inf* applications in the other CPU/packet scheduler class. Our simulated web server consisted of a sender application that reads an actual web server trace and sends data using TCP (each send corresponds to an http request in the trace file; the timing and size of each request was taken directly from the information specified in the traces). The publicly-available ClarkNet server traces were employed to simulate the web server workload [4]. We increased the number of *Net\_inf* applications in the best-effort class and measured their impact on the throughput of the web server. The experiment was then repeated for vanilla Linux. Figure 9 depicts our results. Observe that, the web server simulates the http protocol which runs on TCP. TCP employs congestion control mecha-

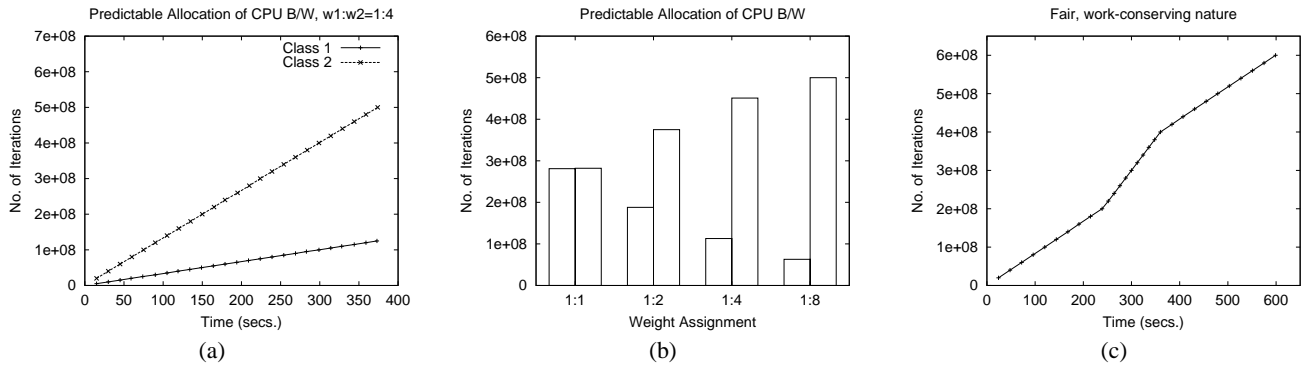

Figure 5: Predictable, fair allocation of processor bandwidth by the H-SFQ scheduler

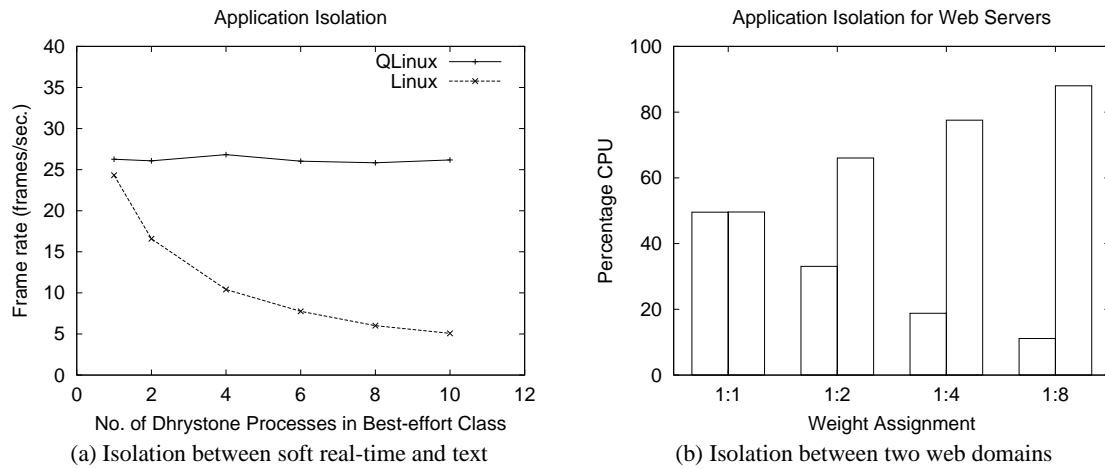

Figure 6: Application isolation and flexibility in the H-SFQ CPU scheduler.

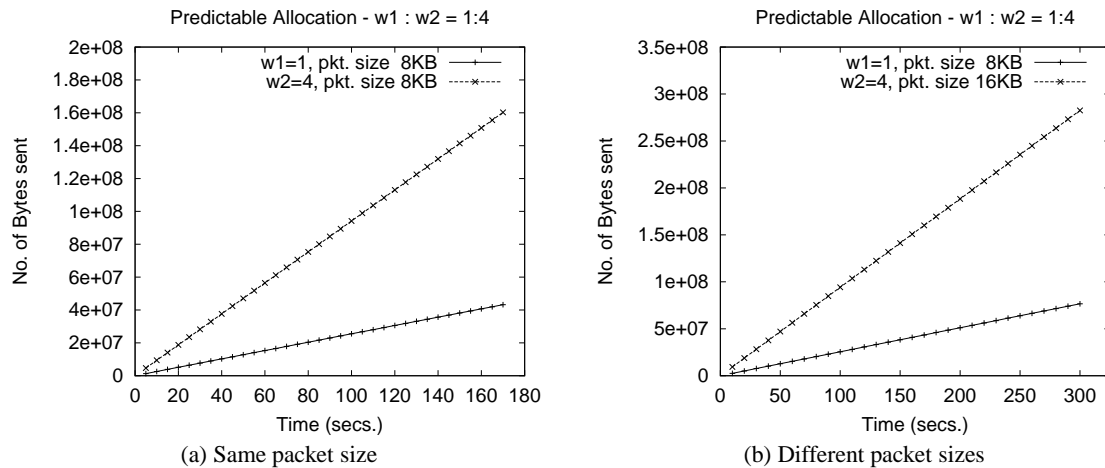

Figure 7: Predictable allocation in the H-SFQ Packet Scheduler.

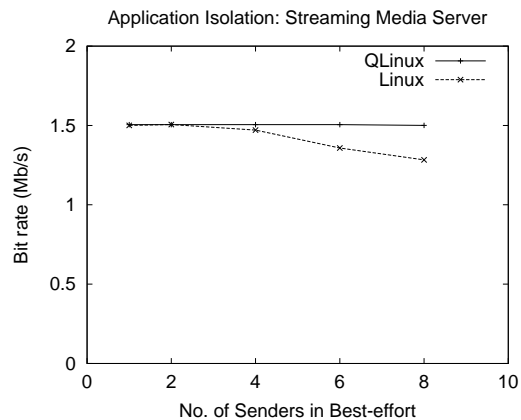

Figure 8: Application isolation in the H-SFQ Packet Scheduler.

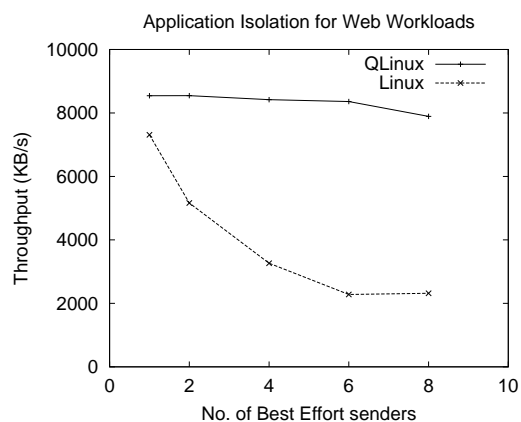

Figure 9: Impact of the H-SFQ CPU and packet schedulers on web workloads.

nisms that back off in the presence of congestion. Consequently, as the load due to *Net\_inf* applications increases, congestion builds up in the ethernet switch interconnecting the senders and receivers (due to the presence of limited buffers at switches), causing TCP to reduce its sending rate. Both QLinux and Linux experience this phenomenon, resulting in a degradation in throughput for the web workload. However, since the QLinux CPU and packet schedulers reserve bandwidth for the web server, they can effectively isolate the web workload from the *Net\_inf* applications. Hence, the degradation in throughput in QLinux is significantly smaller than that in Linux. This demonstrates that use of fair, predictable schedulers for each resource in an OS can yield significant performance benefits to applications.

### 3.5 Appropriate Accounting of Protocol Processing Overheads

To demonstrate the impact of lazy receiver processing, we ran two Apache web servers in QLinux. In the presence of a light load, the response time of a server to retrieve a 1.9KB file was measured to be 50.7ms. We then simulated a simple denial of service attack scenario, in which one server was bombarded with http requests at a high rate (300 reqs/s). In the presence of this load, the response time of the other server (which was lightly loaded) was found to

Table 4: Lmbench Results

Test	QLinux	Linux
syscall overhead	1 $\mu$ s	1 $\mu$ s
fork ( )	400 $\mu$ s	400 $\mu$ s
exec ( )	2 ms	2 ms
Context switch (2 proc/ 0KB)	4 $\mu$ s	1 $\mu$ s
Context switch (16 proc/ 64KB)	286 $\mu$ s	283 $\mu$ s
Local UDP latency	47 $\mu$ s	53 $\mu$ s
Local TCP latency	83 $\mu$ s	82 $\mu$ s
File create (0 KB file)	21 $\mu$ s	21 $\mu$ s
File delete (0 KB file)	2 $\mu$ s	2 $\mu$ s

be 70.1ms. We then repeated the experiment on vanilla Linux and found the response time of the lightly loaded web server to be 79.8ms. Since LRP ensures that protocol processing overheads for a packet are charged to the application receiving that packet, the lightly loaded server is not charged for the packets received by the overloaded server. Hence, it provides a better response time to its requests (note that, some degradation in response time is inevitable due to the congestion control mechanism in TCP and the increased load). Linux, on the other hand, does not account for protocol processing overheads in the same manner, resulting in a greater degradation in response time. This demonstrates that proper accounting of kernel overheads can improve application performance and help isolate unrelated applications during overloads or denial of service attacks.

### 3.6 Microbenchmarking QLinux: Scheduling Overheads

In the previous sections, we demonstrated that applications can benefit from the sophisticated resource management techniques employed by QLinux. In what follows, we measure the overheads imposed by these mechanisms using microbenchmarks.

To measure the overhead imposed by the CPU scheduler, we created a leaf node and ran a solitary *Inf* process in that class. We then progressively increased the depth of the scheduling hierarchy (by introducing intermediate nodes between this leaf and the root) and measured the bandwidth received by *Inf* in each case. Observe that, increasing the depth of the scheduling hierarchy may increase the scheduling overhead (since H-SFQ recursively calls the scheduler at each intermediate node until a thread in the leaf class is selected). A larger scheduling overhead will correspondingly reduce the bandwidth received by applications (since a larger fraction of the CPU time would be spent in making scheduling decisions). Figure 10(a) plots the number of iterations executed by *Inf* in 300 seconds as we increase the depth of the scheduling hierarchy. As shown in the figure, the bandwidth received by *Inf* is relatively unaffected by the increasing scheduling overhead, thereby demonstrating that the overheads imposed by H-SFQ are small in practice.

We then performed a similar experiment for the H-SFQ packet scheduler. The experiment consisted of running the *Net\_inf* process in a scheduling hierarchy with increasing depth and measuring the bandwidth received by *Net\_inf* in each case. As in the case of the CPU scheduler, the bandwidth received by *Net\_inf* was relatively unaffected by the scheduling overhead (see 10(b)). Together, these experiments show that hierarchical schedulers such as H-SFQ are feasible in practice.

### 3.7 Benchmarking QLinux

In our final experiment, we employed the widely used *Lmbench*



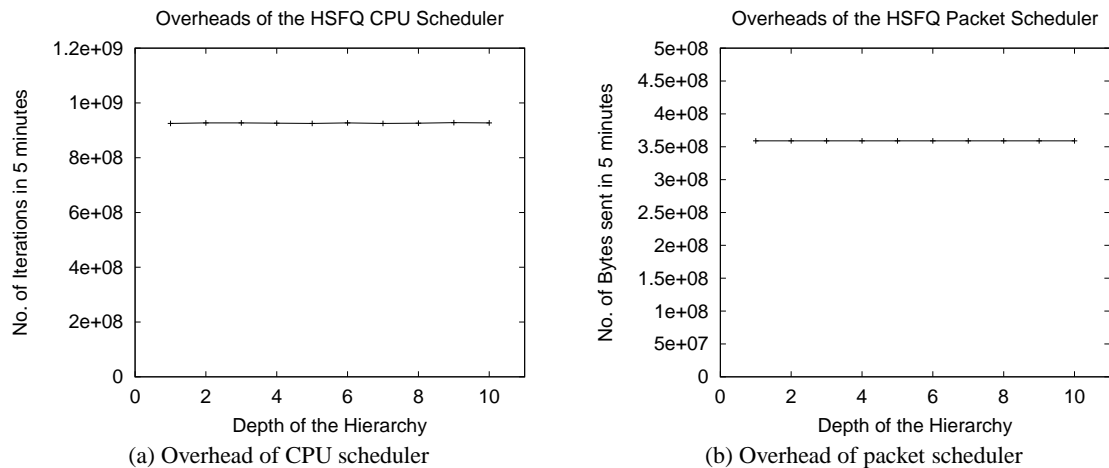

Figure 10: Microbenchmarking QLinux: overheads imposed by the CPU and Packet Schedulers

benchmark to compare QLinux and Linux. Lmbench is a sophisticated benchmark that measures several aspects of system performance, such as system call overheads, context switch times, network I/O, file I/O and memory performance [10]. We employed Lmbench version 1.9 for our experiments. We first ran Lmbench in the default best-effort class on QLinux and then repeated the experiment on Linux. In each case, we averaged the statistics reported by Lmbench over several runs to eliminate experimental error. Table 4 summarizes our results (Lmbench produces a large number of statistics; we only list those statistics that are relevant to QLinux).

Note that the QLinux code is untuned, while Linux code is carefully tuned by the Linux kernel developers. Table 4 shows that the performance of QLinux is comparable to Linux; however, the increased complexity of the QLinux schedulers do result in a larger overhead. For instance, the context switch overhead increases from  $1 \mu\text{s}$  to  $4 \mu\text{s}$  for two active processes; however this overhead is still several orders of magnitude smaller than the quantum duration of 100 ms. The network latency for TCP and UDP, as well as file I/O overheads and system call overheads are comparable in both cases.

#### 4. Related Work

The growing popularity of the multimedia applications has resulted in several research efforts that have focused on the design of predictable resource allocation mechanisms. Consequently, in the recent past, several techniques have been proposed for the predictable allocation of processor [7, 9, 14, 21, 22], network interface [3, 5, 8, 18] and disk [1, 11, 23] bandwidth. While each effort differs in the exact mechanism employed to provide predictable performance (e.g., admission control, rate-based allocation, fair queuing), the broad goals are similar—add quality of service support to an operating system. The key contribution of QLinux is to synthesize/integrate many of these mechanisms into a single system and demonstrate the benefits of this integration on application performance. Whereas the mechanisms instantiated in QLinux are based on our past work in this area, we believe that it would have been relatively easy to implement some other predictable resource allocation mechanisms and demonstrate similar benefits.

Some other recent operating system efforts have also focused on the design of predictable resource allocation mechanisms. The Nemesis operating system, for instance, employs mechanisms that provide quality of service guarantees when allocating processor,

network and disk bandwidth [1, 16]. Unlike QLinux, which employs weights to express resource requirements, Nemesis requires applications to specify their resource requirements in terms of tuples  $(s, p, x)$ , where  $s$  units of the resource are requested every  $p$  units of time, and  $x$  is the additional bandwidth requested, if available. Nemesis is a multi-service multimedia operating system that was designed from the grounds up; QLinux, on the other hand, builds upon the Linux kernel and benefits from the continuing enhancement made to the kernel by the Linux developers. The Eclipse operating system, based on FreeBSD, is in many respects similar to QLinux [2]. Like QLinux, Eclipse employs hierarchical schedulers to allocate OS resources (the actual scheduling algorithms that are employed are, however, different). Eclipse employs a special file system called `/reserv` that is used by applications to specify their resource requirements [2]. QLinux and Eclipse are independent and parallel research efforts, both of which attempt to improve upon conventional best effort operating systems. Finally, many commercial operating systems are beginning to employ some of these features. High end versions of Solaris 2.7, for instance, include a resource manager that enables fine-grain allocation of various resources to processes and process groups [20].

#### 5. Concluding Remarks

Emerging multimedia and web applications require conventional operating systems to be enhanced along several dimensions. In this paper, we presented the QLinux multimedia operating system that enhances the resource management mechanisms in vanilla Linux. QLinux employs four key components: the H-SFQ CPU scheduler, the H-SFQ packet scheduler, the Cello disk scheduler and the lazy receiver processing-based network subsystem. Together, these mechanisms ensure fair, predictable allocation of processor, network and disk bandwidth as well as accurate accounting of resource usage. We experimentally demonstrated the efficacy of these mechanisms using benchmarks as well as common multimedia and web applications. Our experimental results showed that multimedia and web applications can indeed benefit from predictable resource allocation and application isolation offered by QLinux. Furthermore, the overheads imposed by these mechanisms were shown to be small. Based on these results, we argue that all conventional operating systems should be enhanced with such mechanisms to meet the needs of emerging applications.

As part of future work, we plan to enhance QLinux along several dimensions. In particular, we are designing resource allocation mechanisms that will enable QLinux to scale to large symmetric multiprocessors and clusters of servers.

### Acknowledgments

T R. Vishwanath helped us develop the initial version of QLinux. Raghav Srinivasan helped with implementation of the Cello disk scheduler in QLinux. Gisli Hjalmtýsson provided useful inputs during the inception of QLinux in the summer of 1998. Finally, we thank the many users of QLinux and the research community for providing valuable feedback (and bug reports) for enhancing QLinux.

### 6. REFERENCES

- [1] P. Barham. A Fresh Approach to File System Quality of Service. In *Proceedings of NOSSDAV'97, St. Louis, Missouri*, pages 119–128, May 1997.
- [2] J. Blanquer, J. Bruno, M. McShea, B. Ozden, A. Silberschatz, and A. Singh. Resource Management for QoS in Eclipse/BSD. In *Proceedings of the FreeBSD'99 Conference, Berkeley, CA*, October 1999.
- [3] S. Chen and K. Nahrstedt. Hierarchical Scheduling for Multiple Classes of Applications in Connection-Oriented Integrated-Services Networks. In *Proceedings of IEEE International Conference on Multimedia Computing and Systems, Florence, Italy*, June 1999.
- [4] ClarkNet Web Server Traces. Available from the Internet Traffic Archive <http://ita.ee.lbl.gov>, 1995.
- [5] A. Demers, S. Keshav, and S. Shenker. Analysis and Simulation of a Fair Queueing Algorithm. In *Proceedings of ACM SIGCOMM*, pages 1–12, September 1989.
- [6] P. Druschel and G. Banga. Lazy Receiver Processing (LRP): A Network Subsystem Architecture for Server Systems. In *Proceedings of the 2nd Symposium on Operating System Design and Implementation (OSDI'96), Seattle, WA*, pages 261–275, October 1996.
- [7] P. Goyal, X. Guo, and H.M. Vin. A Hierarchical CPU Scheduler for Multimedia Operating Systems. In *Proceedings of Operating System Design and Implementation (OSDI'96), Seattle*, pages 107–122, October 1996.
- [8] P. Goyal, H. M. Vin, and H. Cheng. Start-time Fair Queuing: A Scheduling Algorithm for Integrated Services Packet Switching Networks. In *Proceedings of ACM SIGCOMM'96*, pages 157–168, August 1996.
- [9] M B. Jones, D Rosu, and M Rosu. CPU Reservations and Time Constraints: Efficient, Predictable Scheduling of Independent Activities. In *Proceedings of the sixteenth ACM symposium on Operating Systems Principles (SOSP'97), Saint-Malo, France*, pages 198–211, December 1997.
- [10] L. McVoy and C. Staelin. Lmbench: Portable Tools for Performance Analysis. In *Proceedings of USENIX'96 Technical Conference, Available from <http://www.bitmover.com/lmbench>*, January 1996.
- [11] A. Molano, K. Juvva, and R. Rajkumar. Real-time File Systems: Guaranteeing Timing Constraints for Disk Accesses in RT-Mach. In *Proceedings of IEEE Real-time Systems Symposium*, December 1997.
- [12] L. Molesky, K. Ramamritham, C. Shen, J. Stankovic, and G. Zlokapa. Implementing a Predictable Real-Time Multiprocessor Kernel—The Spring Kernel. In *Proceedings of the IEEE Workshop on Real-time Operating Systems and Software*, May 1990.
- [13] J. Nieh, J. Hanco, J. Northcutt, and G. Wall. SVR4UNIX Scheduler Unacceptable for Multimedia Applications. In *Proceedings of 4th International Workshop on Network and Operating System Support for Digital Audio and Video*, pages 41–53, November 1993.
- [14] J. Nieh and M S. Lam. The Design, Implementation and Evaluation of SMART: A Scheduler for Multimedia Applications. In *Proceedings of the sixteenth ACM symposium on Operating systems principles (SOSP'97), Saint-Malo, France*, pages 184–197, December 1997.
- [15] J. Nieh and M. S. Lam. Multimedia on Multiprocessors: Where's the OS When You Really Need It? In *Proceedings of the Eighth International Workshop on Network and Operating System Support for Digital Audio and Video, Cambridge, U.K.*, July 1998.
- [16] Timothy Roscoe. *The Structure of a Multi-Service Operating System*. PhD thesis, University of Cambridge Computer Laboratory, April 1995. Available as Technical Report No. 376.
- [17] P. Shenoy and H M. Vin. Cello: A Disk Scheduling Framework for Next Generation Operating Systems. In *Proceedings of ACM SIGMETRICS Conference, Madison, WI*, pages 44–55, June 1998.
- [18] M. Shreedhar and G. Varghese. Efficient Fair Queuing Using Deficit Round Robin. In *Proceedings of ACM SIGCOMM'95*, pages 231–242, 1995.
- [19] V. Srinivasan, G. Varghese, S. Suri, and M. Waldvogel. Fast Scalable Level Four Switching. In *Proceedings of the ACM SIGCOMM'98, Vancouver, BC*, pages 191–202, September 1998.
- [20] Solaris Resource Manager 1.0: Controlling System Resources Effectively. Sun Microsystems, Inc., <http://www.sun.com/software/white-papers/wp-srm/>, 1998.
- [21] B. Verghese, A. Gupta, and M. Rosenblum. Performance Isolation: Sharing and Isolation in Shared-Memory Multiprocessors. In *Proceedings of ASPLOS-VIII, San Jose, CA*, pages 181–192, October 1998.
- [22] C. Waldspurger and W. Weihl. Stride Scheduling: Deterministic Proportional-share Resource Management. Technical Report TM-528, MIT, Laboratory for Computer Science, June 1995.
- [23] R. Wijayarathne and A. L. N. Reddy. Providing QoS Guarantees for Disk I/O. Technical Report TAMU-ECE97-02, Department of Electrical Engineering, Texas A&M University, 1997.
- [24] K. Zuberi, P. Pillai, and K G. Shin. EMERALDS: A Small-Memory Real-Time Microkernel. In *Proceedings of the 17th ACM Symposium on Operating Systems Principles (SOSP'99)*, pages 277–291, December 1999.